

OUTWARD DIMENSIONS

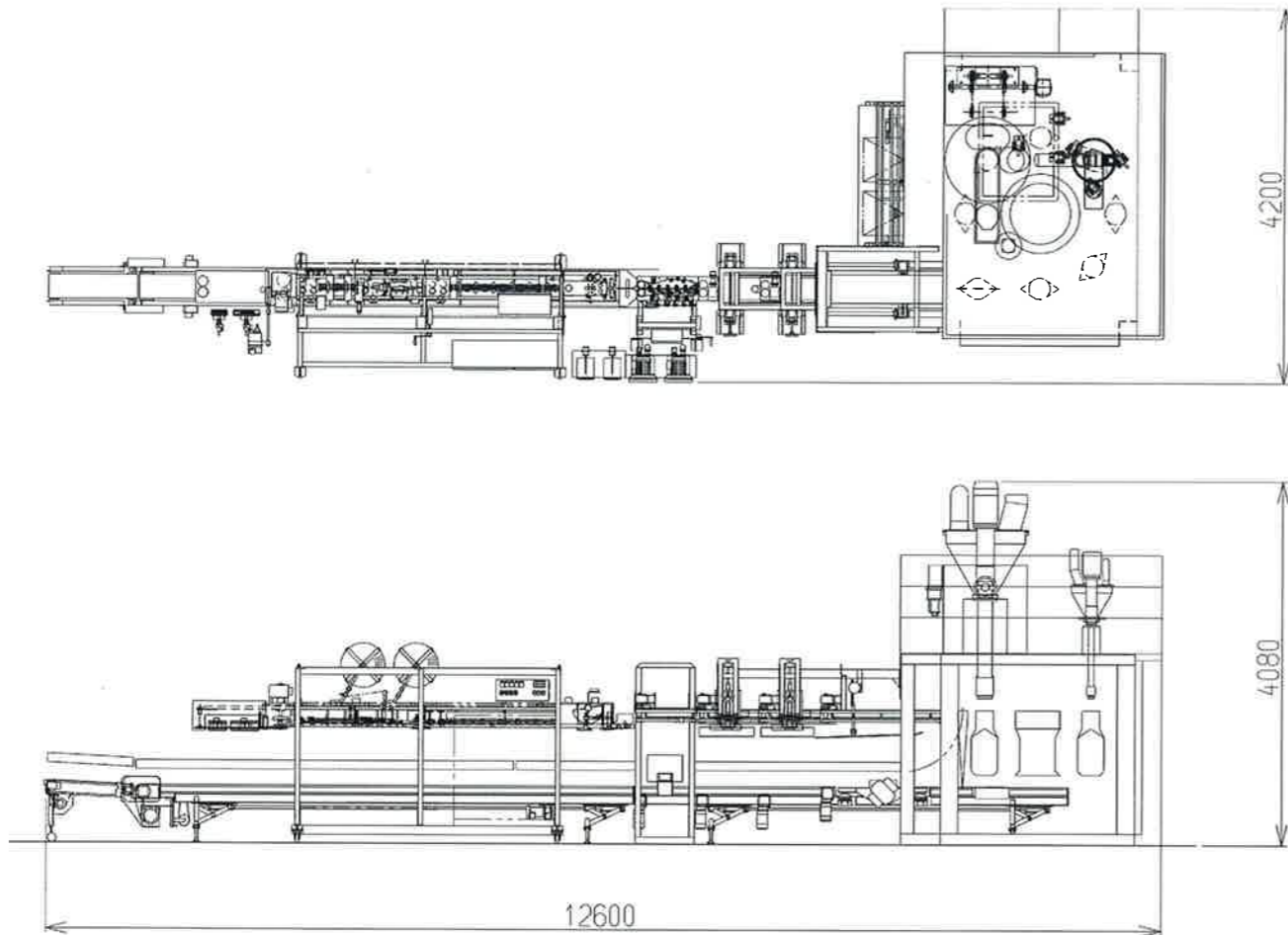

Remark: Drawing includes option.

Contact: AAAMachine, Inc.
1291 Rand Road, Des Plaines, IL 60016
Tel: 847-481-8264, Fax: 847-376-3530
E-mail: aaamachine@aaamachine.com



8-14, Shiratori 4-chome, Katsushika-ku, Tokyo 125-0063, Japan
Tokyo Head Office PHONE +81-3-3603-2276 FAX +81-3-3603-2253
Mechanical Design Engineering Dept PHONE +81-3-3603-2252 FAX +81-3-3602-2694

NLI Group Home Page URL/E-mail

URL <http://nlwww.com/>
E-mail info@nlwww.com



AUTOMATIC BAGGING MACHINE

FG-R-8

Rotary-type Gross Weighing system Automatic Bagging Machine
The operation field can be kept clean (Best bagging machine for environment improvement).

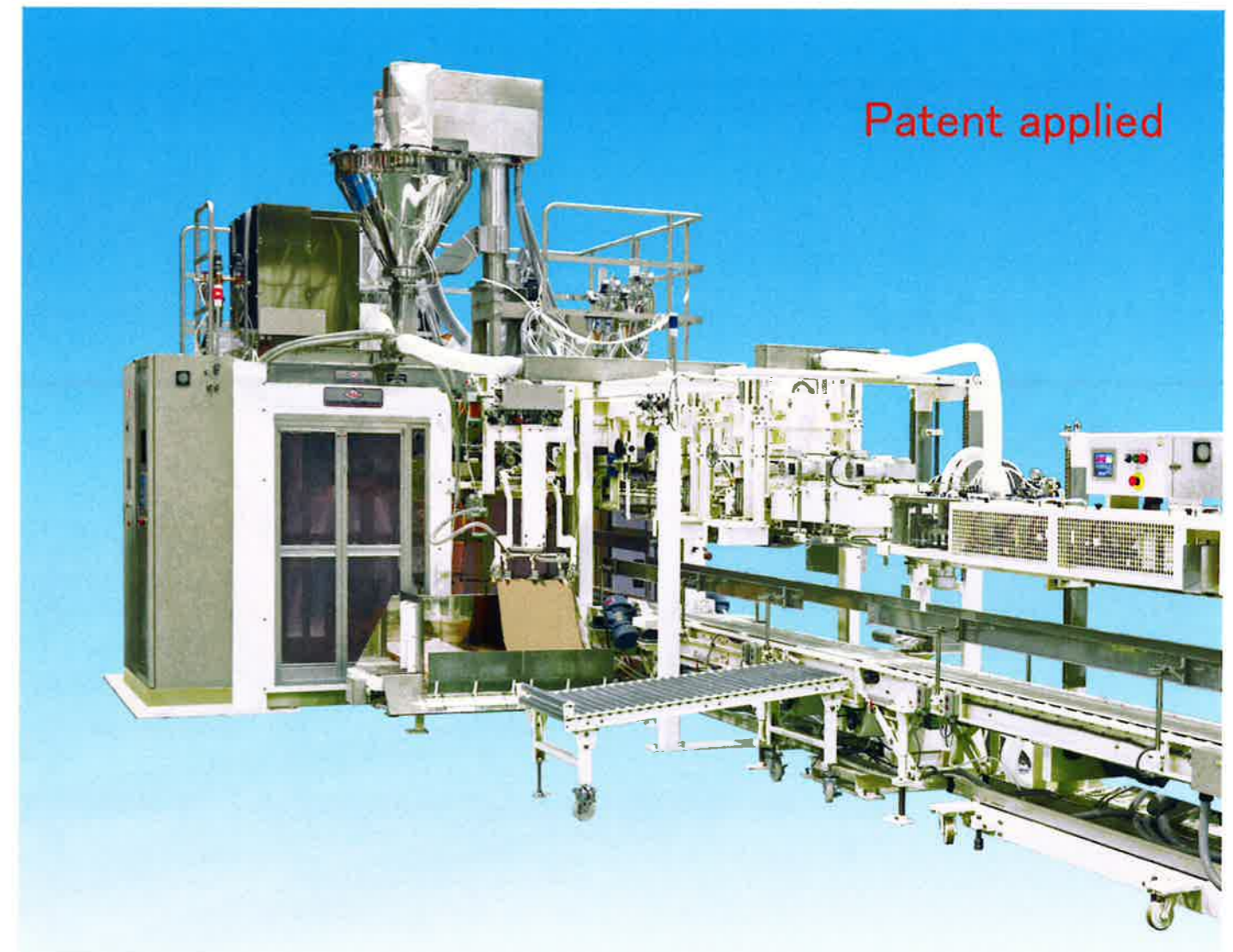

NEWLONG INDUSTRIAL CO., LTD.

AUTOMATIC BAGGING MACHINE

FG-R-8

Rotary-type Gross Weighing system Automatic Bagging Machine
 The operation field can be kept clean (Best bagging machine for environment improvement).

Features

- Ultra High Speed Powder Bagging Machine** (Rotary-type 8 stations method): Filling, Weighing, and Correction Input by 3 stations ensures high capability of powder bagging.
- Minimal Dust Generation** Dust generation is minimal because the products are filled while the gap between product discharge port and product surface is kept minimal using the auger screw type filler (packaging machine liter).
- Stable Accuracy** Auger Screw (single filling method) and built-in load cells are used to weigh and fill the products for high-accuracy and stable weighing and packaging.
- Handles Multiple Products** Compatible with various specifications with ease including powder, fill quantity, etc. There is no contamination since all parts that are in contact with powder can be disassembled for cleaning.

Option

Auger Funnel with Vacuum Deaeration: The auger funnel with vacuum deaeration allows compact filling of bulky powder. The secondary deaerating system enhances the efficiency of deaeration. *Deflating filter can be disassembled for cleaning.

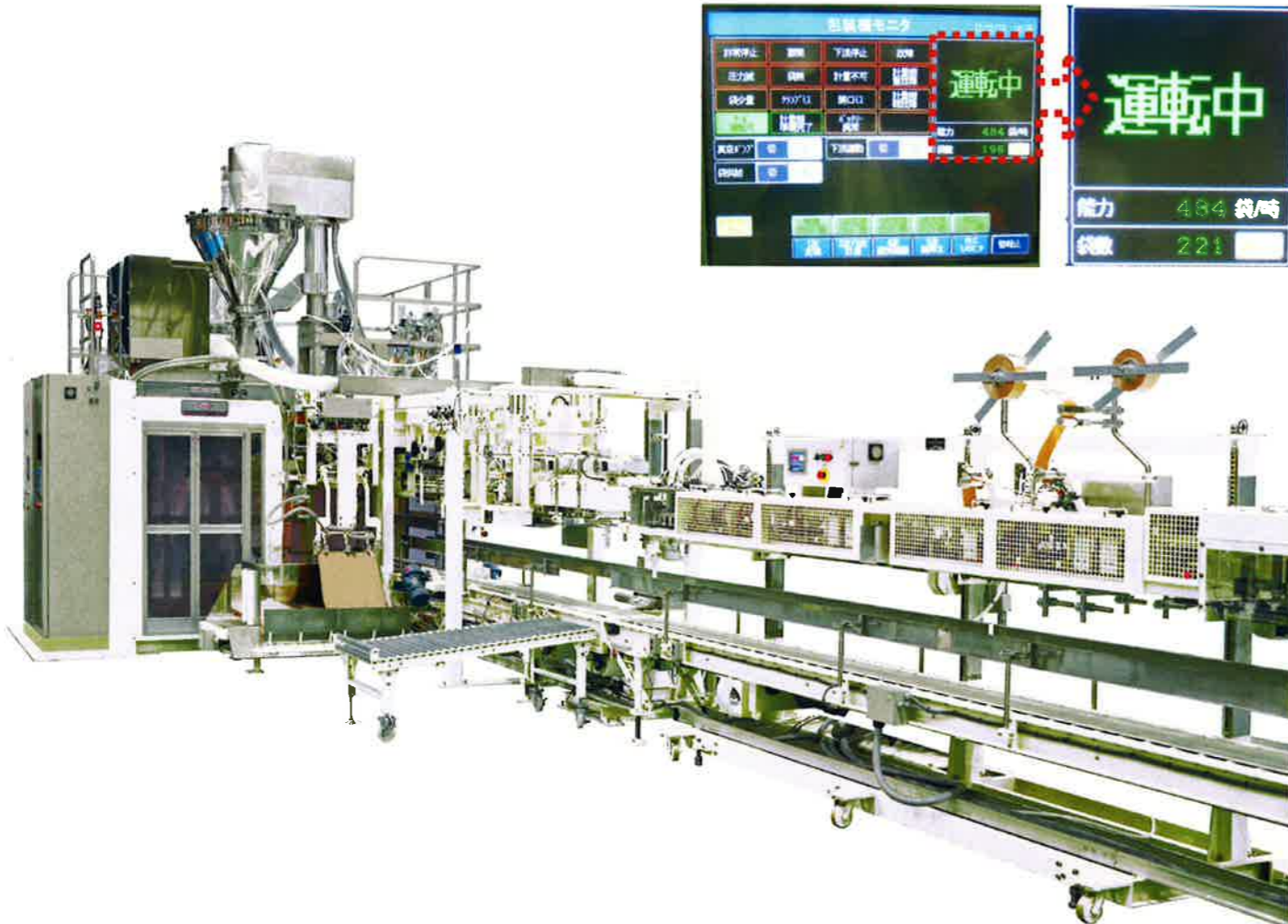

Specifications

Machine Speed	480B/H
Products	Milk Powder, Powder
Set weight	25kg
Bag type	craft paper (double / triple) + inner poly
Bag size	490W x (750) ~ 889L
Bag feeder	2 blocks (Push-on method)
Vacuum Pump	3F, Separate Placement Type
Electronic Power Supply	3phases / 200V / 50Hz

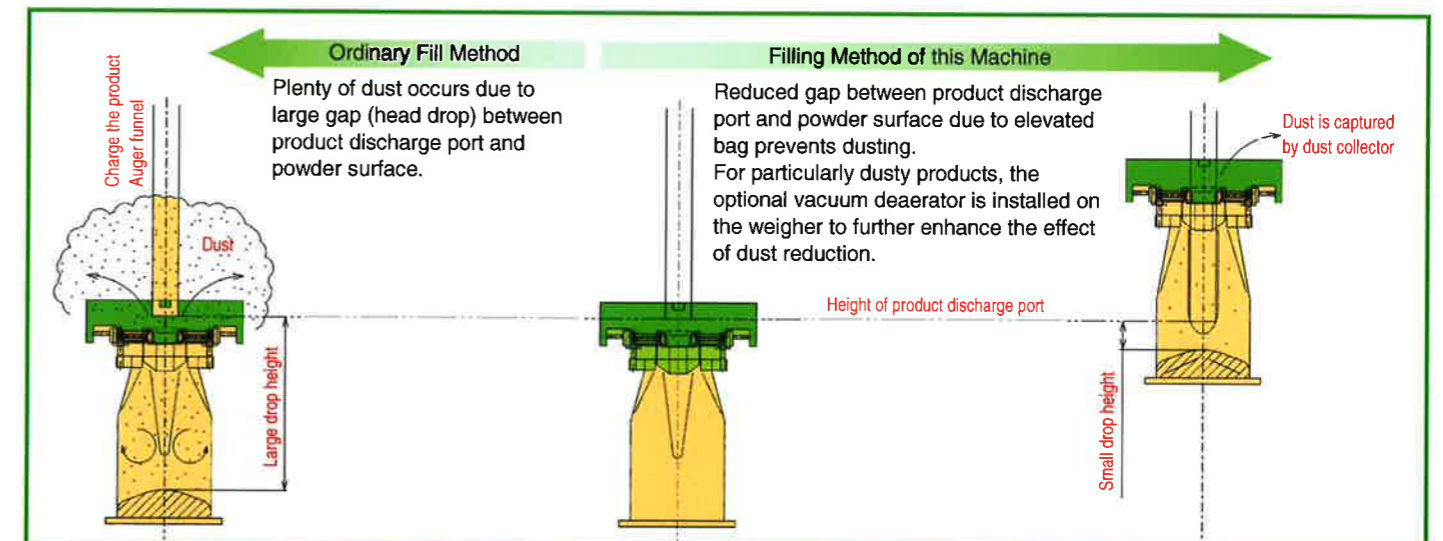

● Specifications subject to change without notice. While due caution has been exercised in the production of this brochure, possible differences between pictures and specifications are not intentional.