

THE IMPROVEMENT OF GRINDING AND CLASSIFYING PERFORMANCE USING CLOSED CIRCUIT SYSTEM

KATSUNORI ISHITO¹, SATOSHI AKIYAMA² and ZENNOSUKE TANAKA³

¹ Plant 1st Department, Nisshin Engineering Inc.,

14-1, Koami-cho, Nihonbashi, Chuo-ku, Tokyo, 103-8544, Japan

² Powder Technology Laboratory, Technical Research Center, Nisshin Flour Milling Co., Ltd.,

5-3-1, Tsurugaoka, Oimachi, Iruma-gun, Saitama, 356-8511, Japan

³ Professor, Material Chemical Engineering Department, Okayama University,

3-1-1, Tsushimanaka, Okayama-city, Okayama, 700-8530, Japan

Abstract - In the powder handling process, it is important to control the particle size distribution. Especially for dry process, because of the stickiness or agglomeration of powder, it becomes more difficult to classify and/or grind powder with the finer particle size distribution. In order to save energy cost or running cost, it is recommended to optimize the classification and grinding condition. Using new classification and grinding technology, we discuss the improvement of the classification and grinding performance. This discussion includes closed loop grinding & classification systems, classification with improved dispersion mechanism and other topics. Powder to be discussed in this paper is mainly toner.

NOMENCLATURE

P: perimeter of a projected particle

A: projected surface area

1. INTRODUCTION

As interest becomes sharply focused upon fine particles, such as in the fine ceramics, plastic, mineral and metal powder industry, particle sizes should be in the order of micron or sub-micron range. In this case, classifiers are indispensable for the powder process as well as grinding mills. This means that coarse particles should be sharply discarded from fine particles to determine top size of the products and collect good fine products before grinder to improve the grinding performance without introducing fine powder. This paper illustrates that classification and grinding are both principal technology in sharply adjusting particle sizes and economically grinding particles and shows several up-to-date examples.

2. REQUIREMENTS OF FINE GRINDING AND CLASSIFICATION

There are two typical methods of adjusting the particle size of fine particles. One is grinding and the other is classification. In manufacturing sub-micron particles, the following technique is required for each method. It is important for grinding mills to produce as many “less than 1 μ m particles” as possible, in a short period of time and at an energy efficient cost. On the other hand, it is important for classifiers to remove the coarse particles which remain, even after grinding, at a greater yield and accuracy. Closed circuit system of grinding and classification will be the primary focus of this paper.

3. A MECHANISM OF CLASSIFIERS AND GRINDERS

< CENTRIFUGAL FORCE CLASSIFICATION >

The forced vortex type classifier has a wide range cut point. For instance, micron order to 100 μ m. Precise classification can be achieved with forced particle flows and air flows. A classification chamber rotating type in the forced vortex type can classify particles down to the 0.5 μ m cut point. This is because of the rectification of air flows and the preciseness in the classification mechanism. Typical examples are: Turbo-Classifier, Acucut, . . . etc. Figure 1 illustrates the cross-sectional view of the Turbo-Classifier^{1),2)} (from Nisshin Engineering).

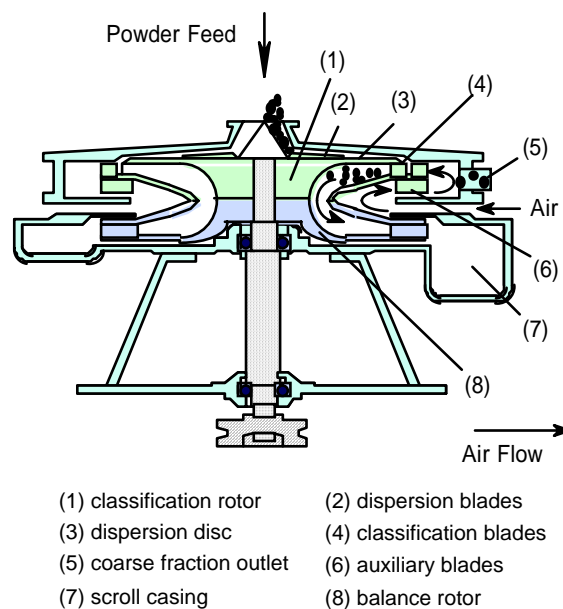

Figure 1 Cross-sectional view of Turbo Classifier

< MECHANICAL MILL >

Jet mills need compressed air and have no moving part. On the other hand, mechanical mills have rotor inside. Figure 2 illustrates the cross-sectional view of the SUPER ROTOR³⁾ (from Nisshin Engineering).

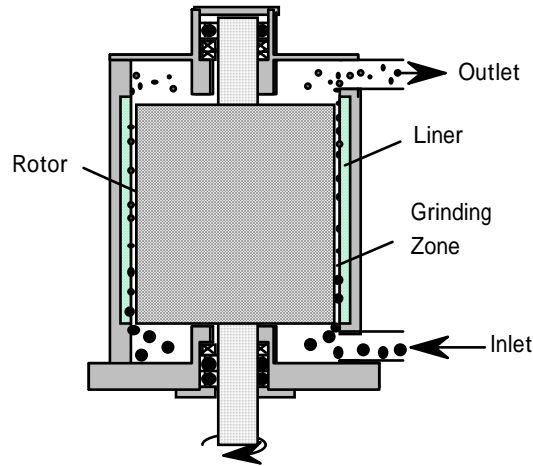

Figure 2 Cross-sectional view of Super Rotor

4. CLOSED CIRCUIT SYTEM WITH A GRINDING MILL & CLASSIFIER

An example of a toner manufacturing process is shown in Figure 3. A closed circuit system of a classifier and a mechanical mill is employed in this process. An effective classification is possible with this system because dispersed particles can be fed to the classifier by the mechanical mill.

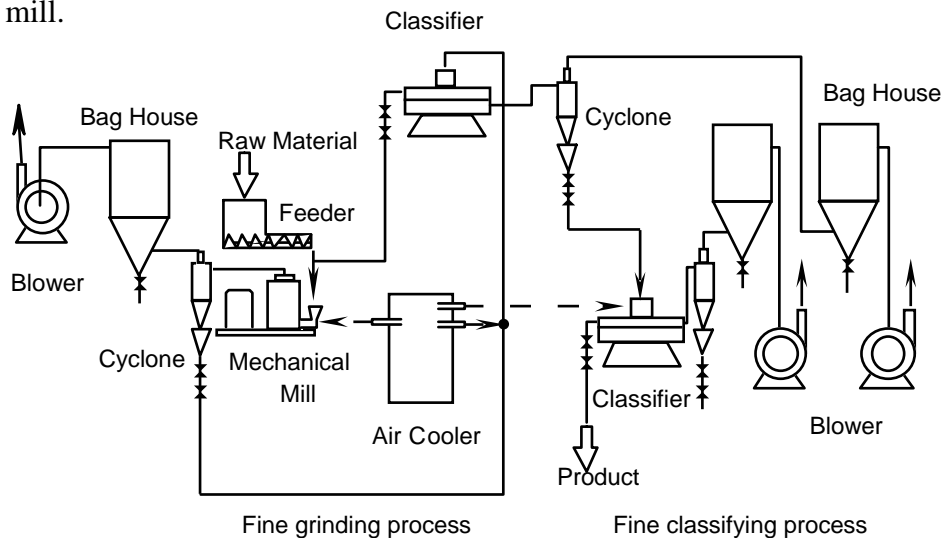

Figure 3 Flowsheet of toner grinding and classifying process

Typically, milled particles have a broad size distribution. For a grinding mill to achieve narrow size distribution products, it would be necessary to operate the mill for an extremely long period of time. Even then, some coarse particles may still remain in the product or the

product may contain too many out-of-spec fine particles. To avoid this situation, classifiers should be incorporated following a grinding mill. A closed circuit system can decrease the load for the grinding mill causing less energy consumption than in a grinding mill-only system.

Today’s copying machines and printers demand improved image quality. This demand has brought with it severe specifications on particle size distribution of toner. Most toner currently available in the market is manufactured by grinding method. Many efforts have been made to increase grinding efficiency in toner manufacture. Higher efficiency is needed because energy increases in grinding and classifying processes as particle size becomes smaller and particle distribution narrower. In the past, jet mills were widely used for toner grinding. However, mechanical mills with higher energy efficiency than jet mills have been developed. These mills can prevent over-grinding and become widely available.

We have developed a closed circuit grinding system coupling a highly efficient mechanical mill and a precision air classifier as follows. Super Rotor SR-25 is used for the mechanical mill. Turbo Classifier TC-25III removes coarse particles in the system.

4.1 COMPARISON BETWEEN JET MILL AND MECHANICAL MILL

Magnetic toner composed of styrene-acrylic binder resin was ground by two kinds of closed circuit grinding systems using the mechanical mill and a conventional jet mill⁴⁾. Particle diameter of the feed material was 500 μm. It was ground in the mechanical mill with air cooled at 5 degree C to prevent from melting the toner during grinding.

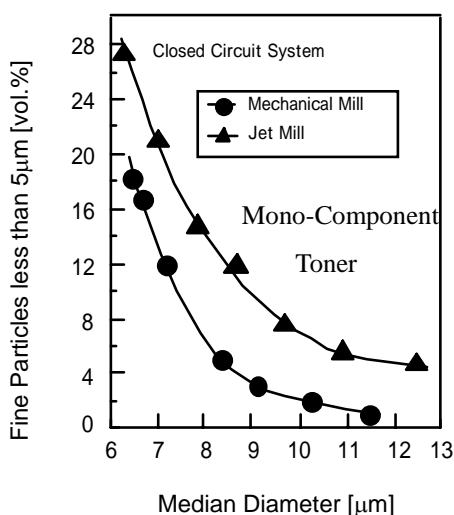

Figure 4 Relation between the median diameter of product and the volume percentage of fine particles less than 5μm

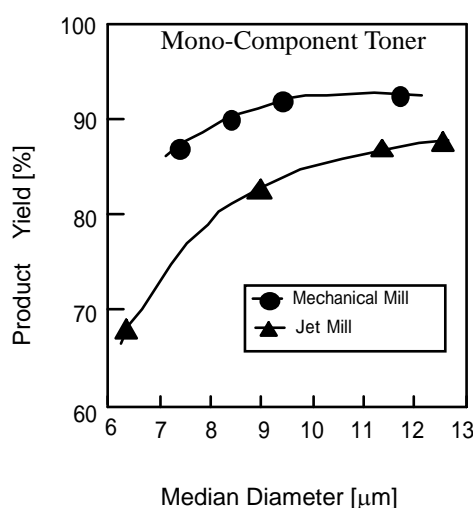

Figure 5 Relation between the median diameter and product yield in grinding and classifying process

Figure 4 compares the mechanical grinding system with the jet grinding system in terms of the over-grinding. The percentage of fine particles less than 5 μm was smaller with the mechanical grinding system than with the jet grinding system.

The fine particles less than 5 μm of those ground toner were removed by an air classifier. The Turbo Classifier TC-40II was used for fine classification. Figure 5 shows product yield with each system. For the same median particle size, the product yield with the mechanical grinding system was higher than that with the jet grinding system, because the mechanical grinding system produced fewer particles less than 5 μm .

Figure 6 shows the relation between the median particle diameter of product and the specific energy consumption of the grinding system. The air compressor in the jet grinding system consumes 70% or more of the total energy. The energy consumed by the air cooler is included in the values shown for the mechanical grinding system. When using the mechanical grinding system, if particle diameter became finer than 8 μm , although energy consumption increased, that consumption was still 40% less than with the jet grinding system.

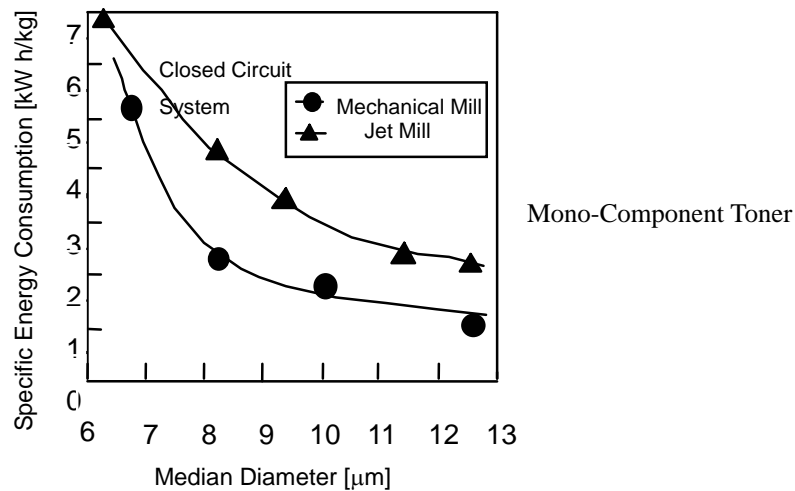

Figure 6 Relationship between the median diameter of product and specific energy consumption of closed circuit grinding system

4.2 TEMPERATURE CONTROL FOR MECHANICAL MILL

Color copiers and printers require color toner that is non-magnetic and made from polyester resin (in most cases). In general, the polyester resin has a low melting point compared with styrene-acrylic resin. Non-magnetic toner with polyester resin is more difficult to be ground than magnetic toner with styrene-acrylic resin. Therefore, an efficient method for grinding color toner is needed.

Magnetic toner with styrene-acrylic resin and non-magnetic toner with polyester resin were ground by the mechanical mill without a classifier. Figure 7 shows the relationship between the rotational speed of the mill and the median particle diameter of product. The non-magnetic toner with polyester resin was more difficult to be ground than the magnetic toner with styrene-acrylic resin. The manufacture of fine toner requires a rotor running at high rotational speed. This causes the outlet temperature of the mill to increase, which means the feed rate of raw material must be decreased.

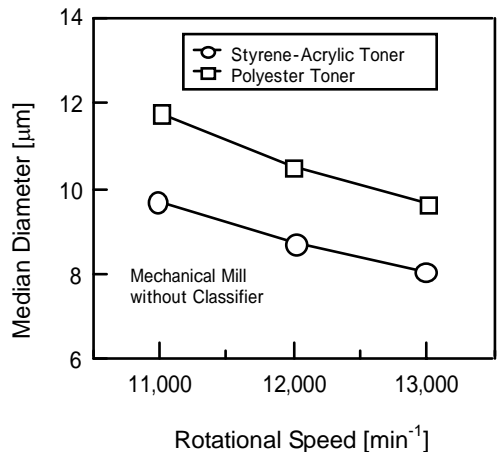

Figure 7 Relation between the rotational speed of mechanical mill and the median diameter of product ground with mechanical mill

Non-magnetic toner with polyester resin was ground to an 8 µm particle diameter by the closed mechanical grinding system. The raw material was fed with the cooling air at various temperatures. Operating conditions were adjusted for an air temperature of 50 degree C at the mill outlet. Figure 8 shows the effect of the temperature of the cooling air on maximum throughput of the mechanical grinding system. By lowering the temperature of the cooling air from 5 to -40 degree C, we were able to increase grinding capability by 2.5 times.

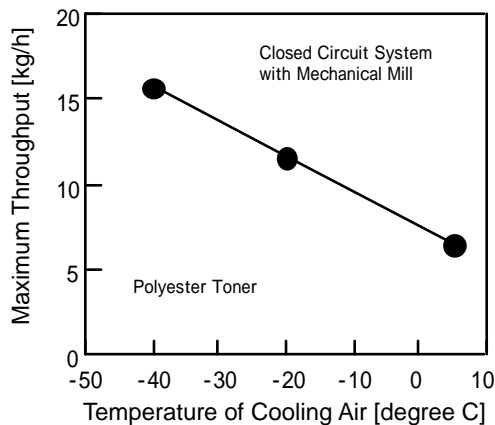

Figure 8 Relation between the temperature of cooling air and the maximum throughput of the mechanical grinding system

4.3 ENERGY CONSUMPTION

Figure 9 shows the relationship between the temperature of the cooling air and the specific energy consumption of the grinding system. The energy consumption in the system increased as the temperature of the cooling air decreased. However, since processing capability was improved, the specific energy consumption required for grinding the toner became rather small.

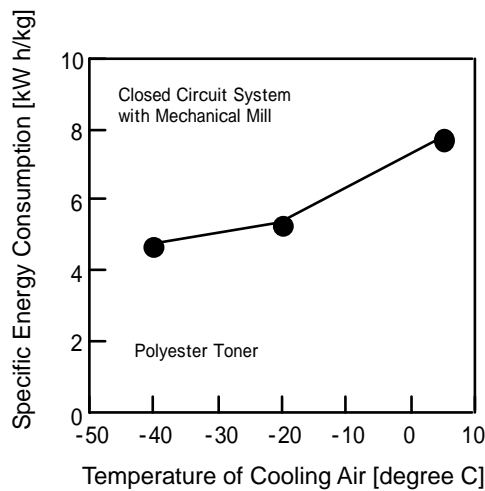

Figure 9 Relation between the temperature of cooling air and the specific energy consumption of closed mechanical grinding system

4.4 PARTICLE SHAPE OF TONERS

Flowability and electrical charge characteristics of toner change with differences in particle shape. Spherically shaped particles hold many advantages. Printing concentration, for example, is deep. Figure 10 shows SEM photographs of the toner ground with a target jet mill system, a pancake jet mill system and the mechanical mill system.

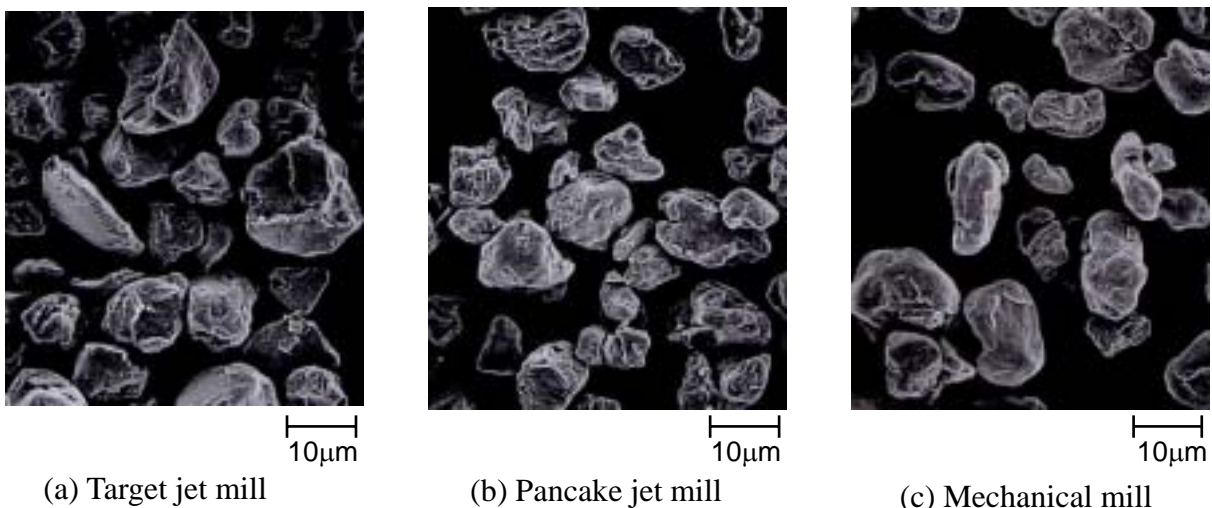

Figure 10 SEM photographs of the toner ground with three kinds of systems

The surface shape factor³⁾ of the toner particles was determined by eq.(1).

$$\text{Surface factor} = P^2/4 A \quad (1)$$

where P is perimeter of a projected particle and A is projected area. If a particle is spherical, its surface shape factor is 1.

Table 1 shows the surface factors for each toner ground with these mills. The surface shape factor was calculated by an image analyzer. Compared with other systems, the mechanical grinding system, with this particle surface shape factor of close to 1, produces the smoothest and rounded surface shape.

Table 1 Surface shape factors for the toner with three kinds of mills

Type of Mill	Surface Shape Factor [-]
Target Jet Mill	1.41
Pancake Jet Mill	1.35
Mechanical Mill	1.26

5. DEVELOPMENT TREND

5.1 TO FIND THE OPTIMUM SYSTEM: (A SYSTEM OF GRINDING MILLS AND CLASSIFIERS)

In advanced closed circuit systems, there are grinding mills with built-in precise classifiers. Typical examples are the Super Hybrid Mill⁷⁾ and AFG Counter Jet Mill. These grinding mills can reportedly produce 0.5 μm (median dia.) particles, although their minimum grinding limit is generally 1 to 3 μm.

A large mechanical mill is often used for grinding minerals (such as calcium carbonate, talc and silica sand) to micron or sub-micron order particles in a high capacity at less cost. A jet mill can also be used for fine grinding; however the jet mill has a high grinding energy cost and is not practical for large capacity grinding. The Super Hybrid Mill (SH Mill) was developed by IHI and Nisshin Engineering to meet these demands. The SH Mill is a Vertical Roller Mill with high performance, and is the result of directly coupling an IHI Roller Mill with a Nisshin Air Classifier.

In order to increase the classification performance, it is very important that the powder fed to the classifier should be dispersed into single particles as completely as possible. When the classifier is used together with the mill, the mill's function is to disperse the agglomerated particles as well as to grind coarse particles into fine. In this way, ground and dispersed particles in mills can be effectively classified by classifiers. In general, if the classifier is

used just after the mill in the system, the fine powder yield is improved by about 5% in the calcium carbonate process. Nisshin and IHI developed the SH Mill with this concept in mind. Figure 11 shows the SH Mill system flow. In order to classify milled powder within 1 second after milling, the air classifier is mounted on the top of the mill part. This mill can classify the powder after the milling process and before re-agglomeration. As a result, the efficiency goes up and a much finer classification point can be attained.

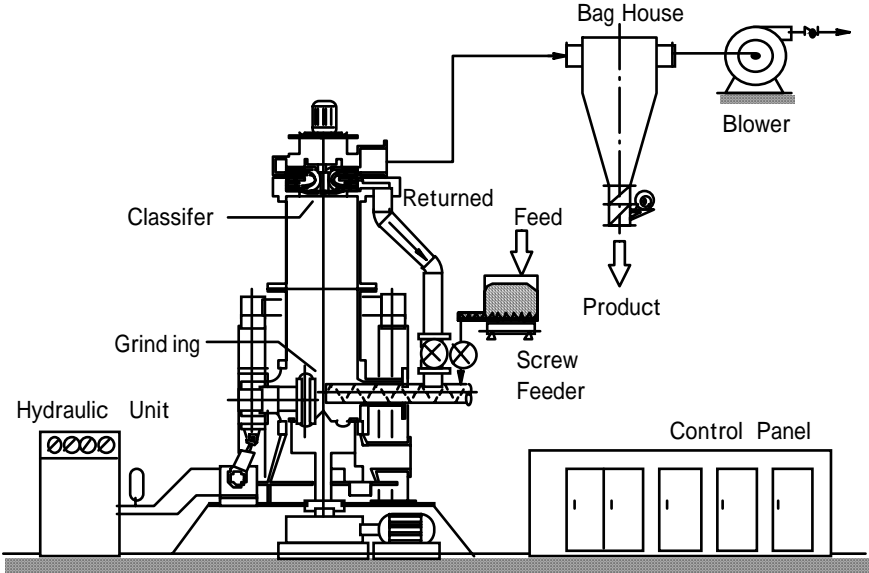

Figure 11 Flow Diagram of Super Hybrid Mill system

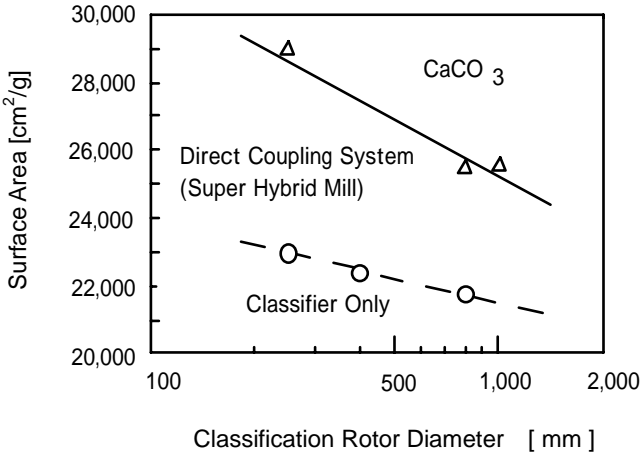

Figure 12 Classification performance improvement by direct coupling

Figure 12 shows the difference in performance between the coupling system and that of the classifier by itself. The SH Mill was used for the direct coupling system, and ground material was classified just after grinding. 10,000 cm²/g (Average Diameter 4 to 5 μm) surface area calcium carbonate was used as both of the Feed to the classifier. The surface area data of the products (SH Mill) and the fine fraction (classifier only) are shown in this figure. The fine yield was controlled 10% for both systems. The following advantages

were obtained with the direct coupling system:

	Small Machine	Large Machine
Classifier Only	23,000 cm ² /g(1.2 μ m D50)	21,500 cm ² /g
Direct coupling	29,000 cm ² /g(1 μ m D50)	25,500 cm ² /g
Advantage	+6,000 cm ² /g	+4,000 cm ² /g

The SH Mill was developed mainly for the purpose of producing a large amount of ultra-fine powder, such as 5 μ m to sub-micron order, at the least cost. Figure 13 shows the performance of the largest model (SH-800) of SH Mill. The TC-120 or TC-130 is used in the SH-800 as the built-in classifier. 3,900 cm²/g talc is produced by the SH-800 with the TC-130 at 800 kg/h feed (product) rate

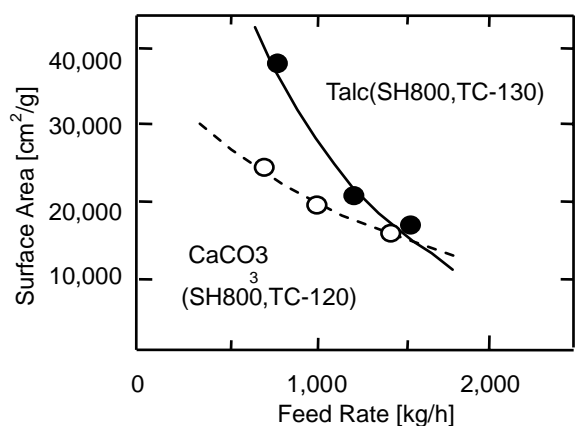

Figure 13 SH-800 Grinding Performance Example

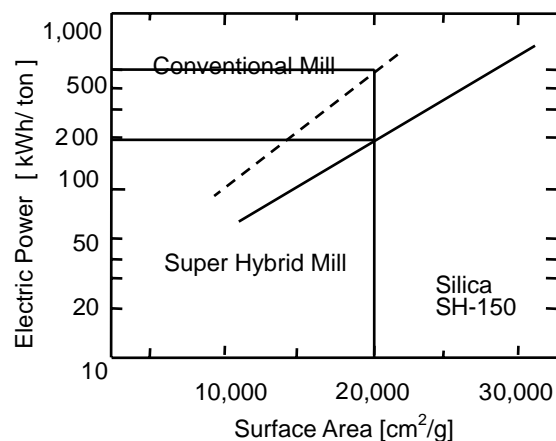

Figure 14 Comparison of electric power usage

Figure 14 shows the difference in electric power usage between the SH Mill and the conventional roller mill. To produce 20,000 cm²/g silica, the SH Mill uses 200 kWh per ton of product compared with 500 kWh per ton for the conventional model. This difference is relatively small in the coarse grinding field, however, it is very big in the fine grinding field. This is typical of the improvement in performance that can be obtained by the direct coupling system over the performance that either machine can deliver separately.

5.2 IN-LINE PARTICLE SIZE MEASUREMENT DEVICE

Although the particle size of products has been measured with off-line devices, in-line devices are introduced by some manufacturers. Classification condition can be monitored by measuring the particle size of the products (or classified coarse powder yield) continuously. This data can automatically adjust the classification conditions through microcomputers. A Laser Method and a classifier method⁸⁾ have been reported.

5.3 MUCH FINER

Already, there is a classifier which can classify down to 0.5 μm cut point in the ceramic field. For toners, 6.5 μm toner could be produced (ground and classified) using a

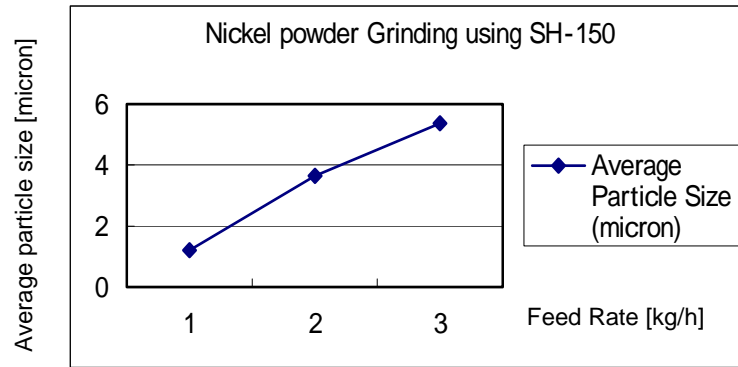

Figure 15 Nickel powder grinding results using SH-150 (TC-25)

mechanical mill. Grinding metal powder, such as Nickel powder, is not easy, because it is generally difficult to be broken. Figure 15 shows the grinding results using SH-150. The combination of grinding (roller mill) and air classification made the products finer and finer. Grinding only can produce 3 to 5 microns average products (Nickel powder). On the other hand, SH-150 can grind nickel powder down to 1.2 microns.

From now on, this closed circuit grinding and classifying system will become popular in the fine grinding field, especially within the equipment.

6. CONCLUSION

- 1) In the toner grinding process, mechanical mill produces less fine particles (below 5 μm) more rounded shape particles than jet mills.
- 2) In the toner grinding process, mechanical mill can be used down to 6.5 μm (average).
- 3) In the toner grinding process, closed circuit system of classifier and mechanical mill gives less energy cost than jet mill above 6.5 μm products (magnetic toner).
- 4) In the toner grinding process, cool air (-40 degree C) increases the capacity of grinding process by 2.5 times compared with 5 degree C normal temperature.
- 5) Grinding mill with built-in classifier increases performance enormously in toners and metal powder field.

REFERENCES

- 1) M. Yasuguchi, Precise Air Classifier TURBO-CLASSIFIER, Industrial Machinery, No. 438, 1987, p80-86
- 2) Y. Yamada , T. Ibori and I. Shimogawa, Effect of Circulating Mechanism on the Air Classifier, Rosemont, IL, 1989, p187-192
- 3) N. Tonoike, S. Akiyama, T. Ichikawa, H. Okabe and K. Ishito: Fine Pulverizing of Heat Sensitive Plastics using Mechanical Mills, Powder and Bulk Solids, 1997, p363-370
- 4) Y. Yamada , O. Kano and K. Yabuta: Coupling System of Air Jet Pulverizer and Air Classifier, Proceedings of the Technical Program, Powder and Bulk Solids, 1992, p205-212
- 5) K. Gotoh, H. Masuda and K. Higashitani: Powder Technology Handbook, Marcel Dekker Inc., 1997, p45
- 6) M. Jimbo, The Newest Ultra-Fine Grinding Process and the Precise Classification Technologies, Epotech, May 31. 1986.
- 7) M. Kano and K. Ishito: Dry Continuous Sub-micron Grinding by Super Hybrid Mill, FC Report, No. 8, 1989, p333-337
- 8) Y. Yamada , M. Yasuguchi and K. Iinoya: Development of a Fineness Measuring Air Classifier, Proceedings of the Technical Program, Powder and Bulk Solids, 1985, p411
- 9) Carl K. Ishito: Air Classification Technologies Update, Proceedings of the Technical Program, Powder and Bulk Solids, 1992, p27-36
- 10) K. Ishito, S. Akiyama and Z. Tanaka: The Improvement of Grinding and Classifying Performance, Proceedings of the Technical Program, Powder and Bulk Solids, 2001, p437-450