

Best solution for fine powder

MVSW Series

Applicable to low specific gravity powder

Probe system efficient for build-up, lightweight and robust construction.
Easy maintenance.



Features

- Probe length from 275 up to 15,000mm
- Contact output: SPDT × 1, 250VAC
- Low power consumption (15VA)
- Free voltage

Applications

- Carbon black tank
- Fly ash silo
- Low specific gravity dehydrated cake hopper
- Fine powdered dust silo
- Toner tank
- Terephthalic acid tank

● Specifications

Model	MVSW-S1	MVSW-L1	MVSW-C1
Probe length(L length)	275mm	350 to 2000mm	600 to 15000mm
Power source	20 to 250VAC/DC 50/60Hz		
Power consumption	Max. 15VA		
Contact output	SPDT×1 250VAC 5A(Resistance load)		
Specific gravity	Fine powder : 0.32g/cm ³		
Vibrating frequency	Approx. 400Hz		
Mounting	R1 screw	R1-1/4 screw	R1 screw
Process temperature	-10 to +80°C		
Ambient temperature	-10 to +60°C		
Process pressure	1MPa(10bar)		
Enclosure	IP65		
Painting color	MUNSELL 7.5GY 6/10		
Mass	1.5kg	2.0 to 5.0kg	1.9 to 4.0kg

● Connection diagram

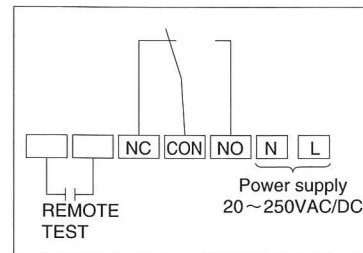
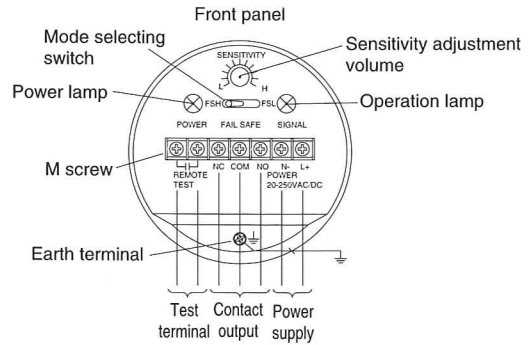

Be sure to ground the earth terminal (D-class grounding)

● Dimension mm

MVSW-S1

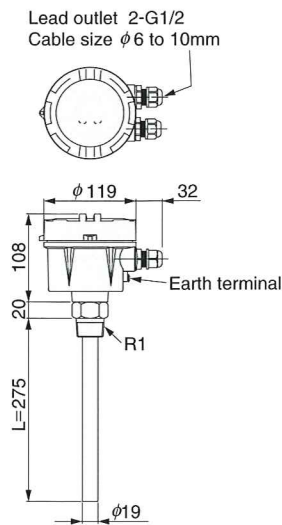

MVSW-L1

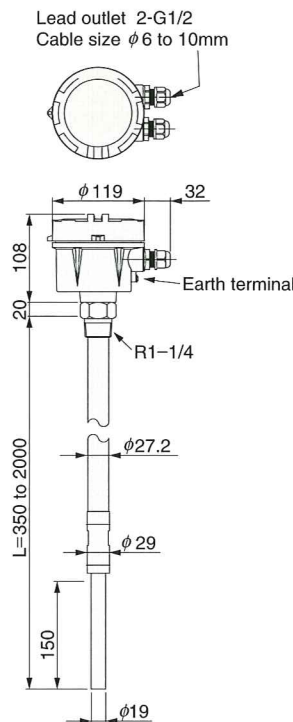

MVSW-C1

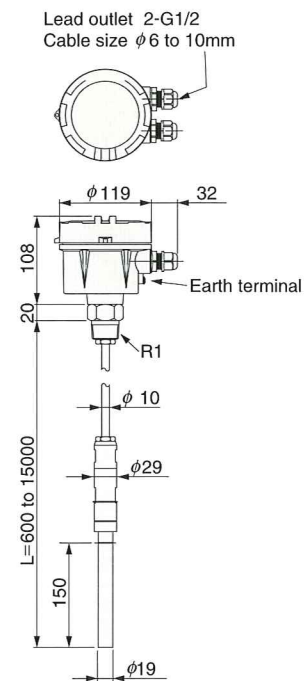

Specifications are subject to change without notice.
All Rights Reserved Copyright © 2010, Matsushima Machinery Laboratory Co.,Ltd.

Caution
● Read the instructions to ensure correct and suitable application of products.
● Contact our nearest sales office when using our products for any systems used in situations which may be life threatening.

Distributor



MATSUSHIMA Machinery Laboratory Co.,Ltd.

HEAD SALES OFFICE / FACTORY
461 Norimatsu, Yahatanishi-ku, Kitakyushu,
807-0831, Japan
Tel: 81-93-691-3731 Fax: 81-93-691-3735

NAGOYA SALES OFFICE
Tokiwasotodoi Bldg., 9-14 Sotodoicho,
Atsuta-ku, Nagoya, 456-0013, Japan
Tel: 81-52-679-6301 Fax: 81-52-679-6305

TOKYO SALES OFFICE
Hohmest Funabashi Bldg., 3-36-28 Honcho,
Funabashi, Chiba, 273-0005, Japan
Tel: 81-47-424-9901 Fax: 81-47-424-9905

OSAKA SALES OFFICE
Daihatsu Bldg., 2-2-40 Katamachi,
Miyakojima-ku, Osaka, 534-0025, Japan
Tel: 81-6-6352-8011 Fax: 81-6-6352-8012

http://www.matusima.co.jp E-mail:info@matusima.co.jp